

|| UTKARSH ||



UTKARSH

**Bluetooth & USB Enabled 3-inch (80mm) Desktop Thermal
Printer with Auto Cutter**

For Technical / Installation Related Support:

Mobile: +91 84471 41431, +91 88001 32259

Landline: +91 124 430 0223

Email: info@bluprints.in

Website: www.bluprints.in

KNOW YOUR DEVICE

POWER SWITCH



The Power switch is located on the front side of printer. When it pushed to the “_” side, the printer is switched on; when the “O” of the switch is pressed, the printer is switched off.

PAPER FEED - Single Press of the Button releases (feeds) paper

TEST PRINT – Hold down FEED button and turn on the printer at the same time to print self-test: Name, Battery Status, Communication Mode, Firmware Version

RED – FOR ERROR CONDITIONS:
(Note: 1 Blink = Half Second ON, then OFF)

- 1. Cutter is stuck in the printer:** Red LED Blinks for 10 times continuously
- 2. Platen Open:** Red LED Blinks twice every 3 Seconds
- 3. NO Paper:** Red LED Blinks four times after every 3 Seconds
- 4. Print Head getting Too Hot:** Red LED Blinks eight times after every 3 Sec.

NOTE: If multiple errors occur together, then the number blinks will add up.

GREEN – FOR POWER ON

RED- Paper detection light, the printer is out of paper when the light is on. Once paper is supplied, the light turns off.

FRONT VIEW

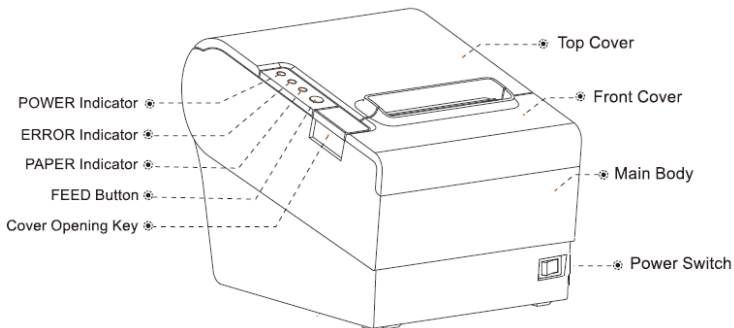

REAR VIEW

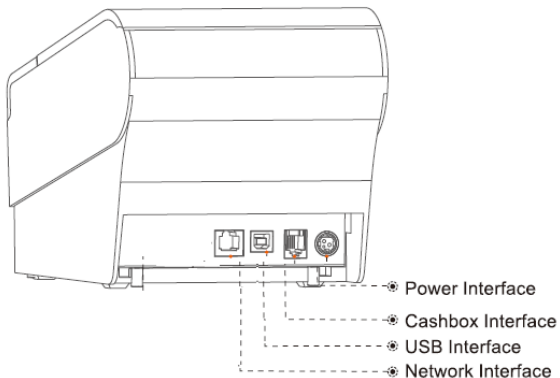

Note: Network Interface is only available in Premium Model.

INSIDE VIEW

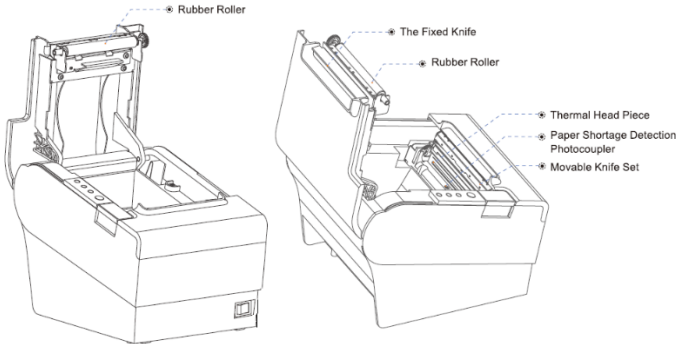

PRINTER SERIAL NUMBER (ON THE LABEL)

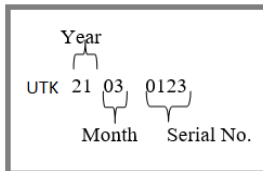



DRIVERS / SOFTWARE / APPS AVAILABLE ON WEBSITE

1	SOFTWARE DEVELOPMENT KIT (SDK)
2	USB DRIVER – 3 INCHES
3	WEB PRINT APPLICATION (AVAILABLE ON DEMAND)
4	DEMO APP – BLUPRINTS SMARTPRINT AVAILABLE ON GOOGLE PLAYSTORE - https://play.google.com/store/search?q=bluprints+smart+print&c=apps



<https://bluprints.in/downloads/>

ACCESSORIES

1.	24 V / 2Amp 220 VAC Power Adapter (BluPrints Branded)	
2.	Shielded USB Data Cable – Type-A to Type-B	
4.	Thermal Paper Roll (3 INCHES)	

THERMAL PAPER INSTALLATION

Thermal Paper roll can print only on one side. To identify the Thermal side, scratch the paper roll on both sides. The side which turns black is the Thermal Side. Keep the paper in such a way that thermal side of the roll is in contact with the printer head.

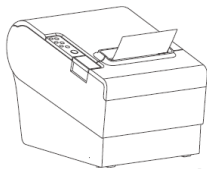
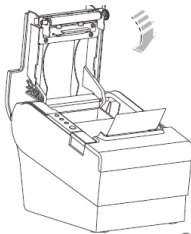
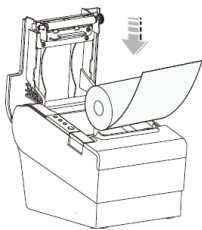

GETTING STARTED

1. Once the printer is switched ON, RED LED will blink a few times while configuring Bluetooth Baud Rate & default parameters of the Printer. Please wait for this process to be completed before using the Device.
2. **If the Printer is not getting switched ON:**
 - a. Check if the Power adapter is properly inserted.
 - b. Check if the adapter is properly plugged into the mains and its Red LED is glowing
 - c. Press FEED Button continuously while turning ON the Power Switch for 3-5 Sec to get test print
3. **Test Print shows following important information:**
 - a. **Bluetooth Name** (e.g.BTprinter1234), which will show on your Bluetooth Phone / tab / laptop.
 - b. **Firmware version**
 - c. **Communication:** shows Bluetooth/USB if both modes are working. It will not show the mode(s) that is/are not working.
4. Bluetooth Passwords for pairing (if required): 1234 or 0000
5. Use proper USB Shielded data cables for proper printing using USB.
6. **If the cutter gets stuck**, turn off the power and restart the Printer. If the cutter is still stuck, then remove this front cover by pulling from both the sides and bring the cutter back in place manually, by rotating the gear.

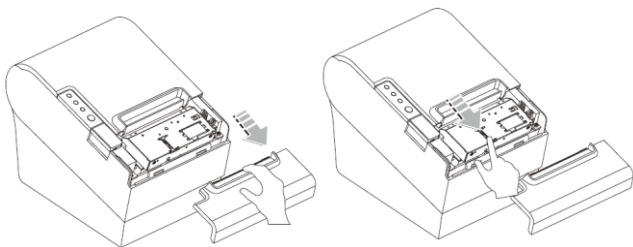

MAIN FEATURES

1. Easy to use device with High Print Quality with low noise.
2. The Printer is Compatible with ESC/POS Instruction Set.
3. The Printer Supports USB, Bluetooth Interfaces
4. The Printer Supports OPOS – OLE for Retail POS, a platform specific implementation of UnifiedPOS, a Point of Sale standard for Windows Operating Systems. OPOS standard specifies two levels for an OPOS control, control object which presents an abstract H/W interface to receipt printer and service object, which handles interface between control object and printer.
5. The Characters can be enlarged, Made Bold and Underlined.
6. The printer supports graphic printing.
7. The Printer consumes low power and has very low operational cost since there is no need for colour tape or ink cartridge.

CONNECTION

Connect the Power Adapter as per following diagram:

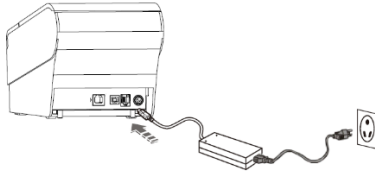

SAFETY WARNINGS

1. Do not touch Paper cutting or tearing knives of the Printer.
2. The Print-Head is a heating component. Do not touch the Print-Head and its surrounding components while printer is still warm.
3. Do not touch the surface of Thermal Print head and connectors, in order to avoid any electrostatic damage to the Print-Head.
4. Do not Wet the Product or insert any metallic objects into it.

USAGE AND CARE INSTRUCTIONS

5. Use original BluPrints 24 Volts 2Ampere Power adapter to ensure better printing quality and printer life. Any other adapter may result in excessive / or low current.
6. Use good quality thermal paper roll (75 GSM) & recommended paper size rolls for better print quality. Other paper types can cause jams and potentially cause damage.
7. Avoid contact with water or any conductive material (such as metal). In case such a thing happens just switch off the device immediately and get in touch with customer support.
8. Ensure that print command is given only when the paper roll is present in the printer and not in a stuck position. Otherwise, it might lead to damage to the printer head.
9. Keep the printer cover closed always to protect it from exposure to dust & sunlight exposure. Do not try to dismantle the device on your own.
10. Keep the printer away from devices like microwaves that can obstruct Wi-Fi or Bluetooth signals.
11. Turn Off the printer when not use it for a long time period.
12. Be sure not to print continuously over 1 meter, otherwise may cause damage to the printer head.
13. Do not open paper case cover or touch paper roll while printing or feeding; otherwise, the printer may working properly.
14. Bluetooth Communication Distance should be within 10m, else it might print junk.
15. Too high (50°C) r too low (10°C) temperature and too high (80%) or too low (20%) relative humidity both affect Print Quality.
16. Normal thermal paper can't be kept too long time, if you need to keep the receipt for a long period, please choose long term effective thermal paper.
17. Connect the printer's power adapter to an appropriate grounding socket. Avoid using the same socket with equipment that may cause voltage fluctuation of power supply.

GENERAL MAINTENANCE

Your Printer Head Needs Cleaning When:



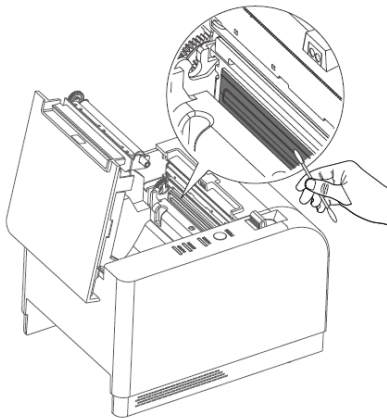

1. Printing is not clear
2. Some of the columns on the printed receipt are not clear
3. Feeding the paper is abnormally noisy.

Procedure to clean the Head:

1. Turn off the printer, disconnect the power cord, open the cover and remove paper roll.
2. If you have just finished printing, wait for the print head to cool completely.
3. Now dip a soft cotton cloth in petrol/spirit/ethyl alcohol and clean the thermal printer head to remove the dust.
4. Wipe again with dry cotton cloth and re-test printer.



DETAILS OF CONNECTORS

	USB	Universal USB Interface (Standard Type B)
	Network interface	Standard RJ45-8P interface, 10M/100M transmission speed with self-adaptation, 100M network LED indication, data communication LED indication.
	Cashbox control	The 6-wire RJ-11 socket, outputting DC 24V/1A power signal to drive the cashbox.
	Power interface	Power plug DC 24V.

Note: Network Interface is only available in Premium Model.

WARRANTY & SUPPORT

BluPrints offers 80 plus PAN-India Service Centres for walk-in resolution to problems for devices in / out of warranty.

The warranty period starts at the time of Product's original purchase, and the date of invoice issued to the customer. The Warranty Period is mentioned on the invoice. If you wish to make a claim under the Limited Warranty, you may call the support phone numbers (where this is available and please note national rates apply to calls) and/or where necessary, return your Product or the affected part (if it is not the entire Product) to our designated service location. Information about, our designated service locations can be found at our website (www.bluprints.in).

Note: If the warranty period is over, service charges and replaced parts charges shall be applicable.

BLUPRINTS PRODUCT RANGE

1. SAMPANN RANGE OF 2 INCH THERMAL PRINTERS (58MM)

- **DESCRIPTION:** Bluetooth & USB Enabled 58MM Mobile thermal Printers with 1100 Mah – 2600 Mah Rechargeable Li-Ion Battery, Charger, USB Cable, Thermal Roll and Carry Case (Optional)
- **CERTIFICATIONS:** BIS, CE, WPC, IP-54, EMI/EMC



**SAMPANN
ECONOMY**



**SAMPANN
REGULAR**



**SAMPANN
PREMIUM**

2. PRAGATI 3 INCH THERMAL PRINTERS (80MM)

- **DESCRIPTION:** Bluetooth & USB Enabled 80MM Mobile thermal Printers with 2000 MAH - 2600 MAH Rechargeable Li-Ion Battery, Charger, USB Cable, Thermal Roll and Carry Case (Optional)
- **CERTIFICATIONS:** BIS, CE, WPC, IP-54, EMI/EMC



**PRAGATI
ECONOMY**



**PRAGATI
REGULAR**

3. VRIDDHI 2 INCH FULLY WIRELESS BIOMETRIC (AADHAR) ENABLED THERMAL PRINTERS – FIN-TECH SERIES

- **DESCRIPTION:** Bluetooth Enabled 58MM Mobile thermal Printers with 1100 MAH Rechargeable Li-Ion Battery, Charger, USB Cable, Thermal Roll, with Built-in Biometric STQC CERTIFIED Finger Print scanner and 1 year RD Services for UIDAI
- **CERTIFICATIONS:** BIS, CE, WPC, IP-54, EMI/EMC, STQC, AEPS



VRIDDHI

BLUPRINTS RANGE OF PRINTER ACCESSORIES



PAPER ROLL



LABEL ROLL



USB TO MINI
USB CABLE



SHIELDED USB
CABLE TYPE A TO
TYPE B



7.4V BATTERY
PRISMATIC



7.4V BATTERY
CYLINDRICAL:



LEATHER BAGS FOR PRINTERS



ADAPTER
5V/1A CABLE USB



ADAPTER
5V/2A USB



ADAPTER
24V/2A